

# JOINTING IN THE CITY OF ROCKS DOME, ALMO, IDAHO

ANNE G. HEREFORD

DEPARTMENT OF GEOSCIENCES, WILLIAMS COLLEGE  
Faculty Sponsor: PAUL KARABINOS

## INTRODUCTION

The City of Rocks dome is part of the Albion Mountains metamorphic core complex. The Almo Pluton intruded the dome at 29 Ma according to U-Pb dating (Forrest et al., 1994). The pluton is now

exposed as the core of the dome in the City of Rocks National Reserve and just north of the City of Rocks in Castle Rocks (fig 1). Following intrusion of the pluton, the rate of uplift increased and the pluton was unroofed as several km of overburden were eroded (Armstrong, 1968). The pluton was exposed by 10 Ma, as evidenced by the contact with a 10 Ma rhyolite (Miller and Bedford, 1999).

The rocks exposed in the City of Rocks dome near Almo, Idaho are extensively jointed. The purpose of my study was to compile a more complete data set of local joint orientations and to relate the joint orientations to documented regional and local geologic events.

## METHODS AND DATA

In an attempt to gather a representative sample of joint

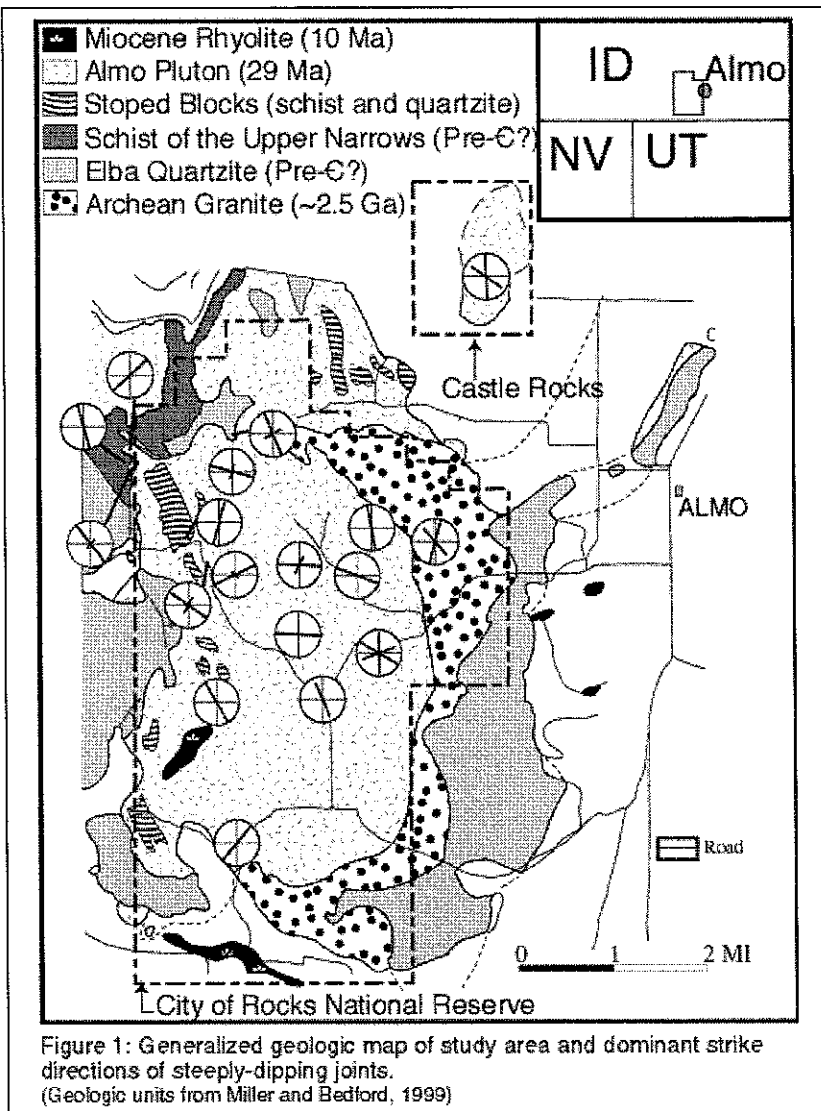

orientations, I measured joints that appeared to be members of prominent joint sets. I measured 412 joints in the pluton and surrounding units. Jamie Levine provided me with 819 measurements of joints in the pluton for use in my analysis. Additionally, Charlie Woodruff shared with me his data collected for a study of mineralized zones in the pluton. Data was plotted using R.W. Allmendinger's Stereonet and David McEachran's Rosy, both programs for Macintosh.

## ***Orientations of steeply-dipping joints and hydrothermally altered zones***

A rose diagram of steeply-dipping joints in the pluton shows three dominant joint sets (fig 2) striking N-S, WNW-ESE and ENE-WSW. These sets are evident to varying degrees at various locations around the pluton (fig 1).

Hydrothermally altered zones strike N-S (fig 3), parallel to one of the dominant joint sets.

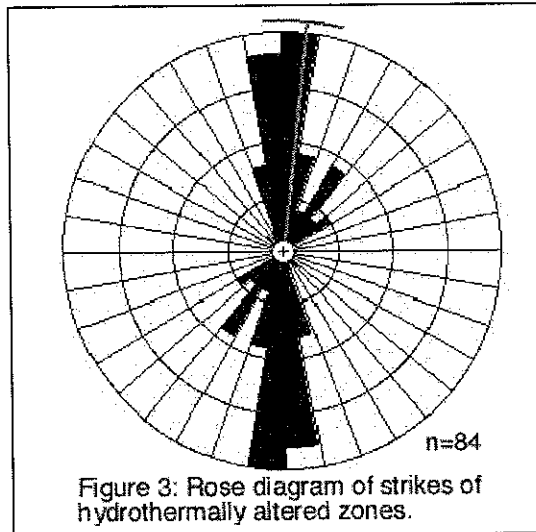
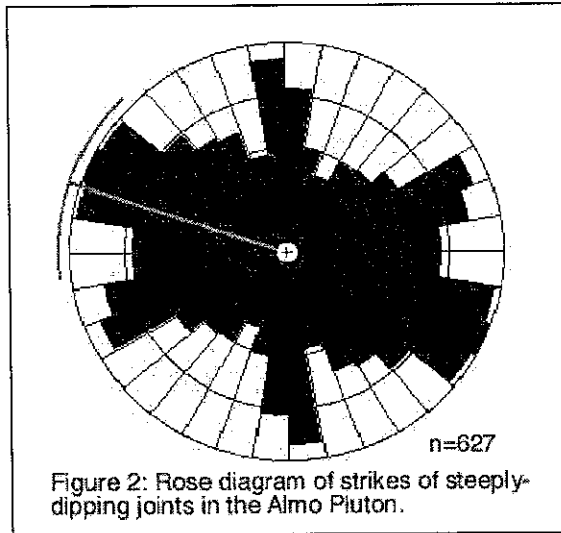

## ***Orientations of shallowly-dipping joints***

A contour plot of all shallow joints measured in the pluton shows a higher concentration of east-dipping joints than west-dipping joints (fig 4).

### ***Joint orientations in surrounding units***

There appear to be two prominent joint sets in the Precambrian granitoid—one striking just east of north and the other striking NW-SE (fig 1). Joints were also measured in the Elba Quartzite at two locations. Both locations contained a dominant set striking NW-SE. Each location showed smaller sets striking 90° from the dominant sets (fig 1). Measurements made in the Schist of the

Upper Narrows exhibit a dominant orientation just west of north (fig 1). Joint measurements were also made in one stopped block. The dominant joint orientation in this block of schist and quartzite strikes 190° (fig 1).

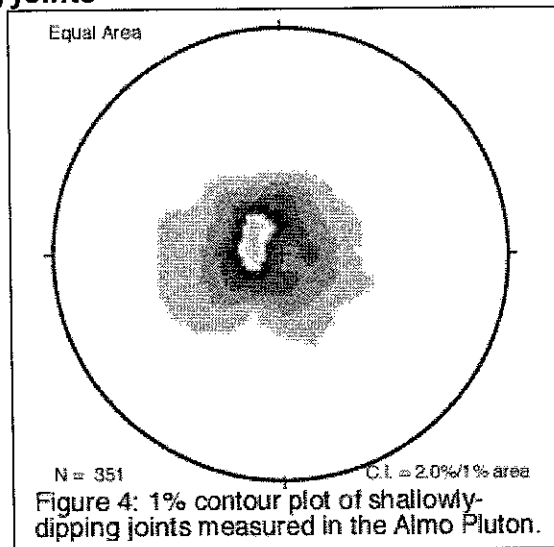

## DISCUSSION

### *Steeply-dipping joints and hydrothermally altered zones*

As the ENE-WSW joint set apparent from the plot of all data collected in the pluton is primarily the result of a high concentration of joints of this orientation in a small area, I argue that this set is not the result of regional stress but of a more localized stress. However, the N-S- and ESE-WNW-striking sets were much more consistently pervasive around the pluton, with the hydrothermally altered zones supporting the prevalence of the N-S set.

Hydrothermally altered zones are mainly oriented N-S to NNE-SSW. The orientations of these mineralized zones have two potential implications. It might be that alteration occurred preferentially along joints perpendicular to the direction of least compressive stress. The other possibility is that at the time of alteration, the N-S joints were the only ones that existed. Charlie Woodruff is currently attempting to date the alteration using samples collected from the zones. This age has the potential to link the alteration to previously established regional events such as the Miocene extensional events documented by Miller and Bedford (1999). These extensional events moved units down to the west and northwest (25 to 20 Ma) and to the east (13 to 9 Ma) (Miller and Bedford, 1999), which implies a direction of least compressive stress compatible with the orientations of the altered zones and the N-S joint set.

The prevalent WNW-ESE joint set is not likely attributable to the aforementioned local extensional events because it is parallel to the direction of least compressive stress. This set is more likely related to stress fields associated with the doming event. The four domes in the region are aligned along a roughly NNE-SSW axis and are separated by depressions with a WNW-ESE trend (fig 5), parallel to the second pervasive joint set.

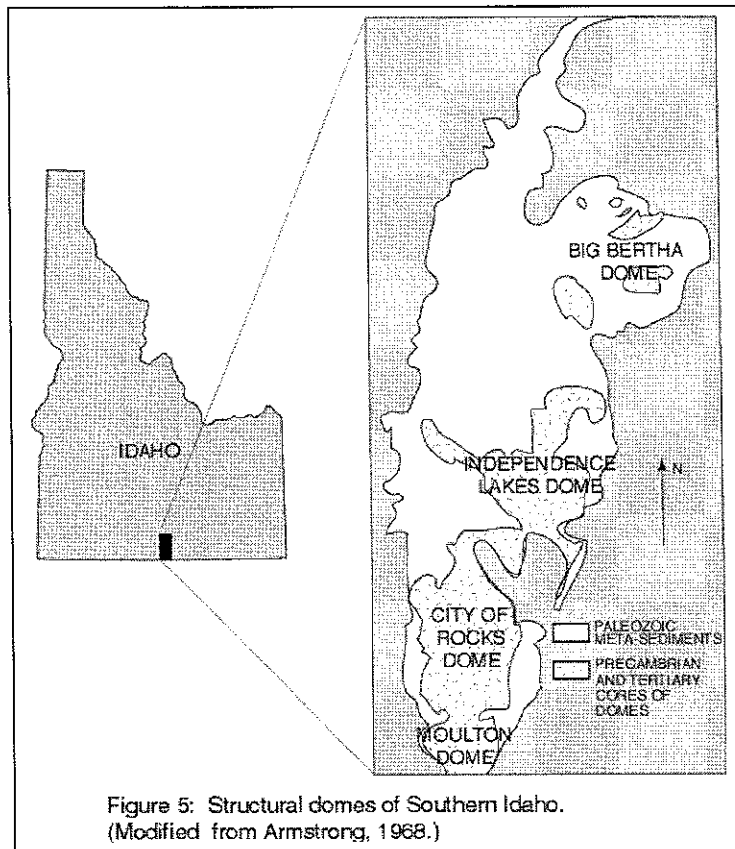

### *Shallowly-dipping joints*

According to observations in the field, shallowly-dipping joints often parallel outcrop surfaces. Glasser (1997) observed a similar relationship in the Cairngorm granite in Scotland. Known as "unloading joints," these structures form because confining pressure is released as erosion and uplift remove the overburden. Erosion occurs preferentially along joints resulting in positive feedback and formation of more joints parallel to the surface. Given current topography, with the highest elevations being to the north and west of the basin in which the Almo Pluton is exposed, it is not surprising that a larger portion of Twenty-two points, plus triple-word-score, plus fifty points for using all my letters. Game's over. I'm outta here. Twenty-two points, plus triple-word-score, plus fifty points for using all my letters. Game's

over. I'm outta here. the shallow joints dip to the east and southeast than in other directions.

## ***Joints in surrounding units***

The older a rock unit is, the more deformation it is likely to have undergone. For this reason, it may be difficult to recognize joint patterns produced from single events. The units surrounding the pluton that were included in this study are all of early Cambrian age or older and thus have been subjected to multiple deformational events including the Antler, Nevadan, Sevier and Laramide Orogenies in addition to the more recent Basin and Range extensional forces. However, several of the units do display discernible joint sets (fig 1). The Elba Quartzite contains a dominant joint set oriented roughly NW-SE and a less-prominent set oriented NE-SW. The two dominant joint sets found in the nearby Precambrian gneiss near have orientations similar to those found in the quartzite–NNE-SSW and NW-SE. Because neither of these joint sets is consistent with the sets found in the Almo Pluton itself, it is likely that the joints are the result of events prior to the intrusion of the pluton, possibly associated with the arching of the City of Rocks dome.

## **CONCLUSIONS**

The rocks of the City of Rocks dome are so extensively jointed that it is impossible to assign an origin to each specific joint orientation. However, dominant sets correlate reasonably well with regional events. Of the steeply-dipping joints, the N-S and WNW-ESE sets are likely related to local extension associated with late Oligocene (?) doming. Shallow joints are primarily the result of unloading although it is likely that all jointing is affected by primary structures established prior to jointing. However, more evidence would be helpful in order to make conclusive statements about the origin and nature of jointing in the City of Rocks dome.

## **ACKNOWLEDGEMENTS**

I would like to acknowledge my patient advisor, Paul Karabinos, for his indispensable advice and our project director, Kevin Pogue, for his long-distance technical support. Thanks also to all the Idaho Keck participants, especially Jamie Levine and Charlie Woodruff for sharing their data.

## **REFERENCES CITED**

- Armstrong, R.L., 1968, Mantled Gneiss Domes in the Albion Range, Southern Idaho: Geological Society of America Bulletin, v. 79, p. 1295-1314.
- Forrest, S.E., Miller, E.L., and Wright, J.E., 1994, Oligocene plutonism and associated crustal thinning in the southern Albion Mountains, Idaho, *in* Anonymous, ed., Geological Society of America, 1994 annual meeting., Volume 26: Abstracts with Programs - Geological Society of America: Boulder, CO, United States, Geological Society of America (GSA), p. 192.
- Glasser, N.F., 1997, The origin and significance of sheet joints in the Cairngorm granite: Scottish Journal of Geology, v. 33, p. 125-131.
- Miller, D.M., and Bedford, D.R., 1999, Pluton intrusion styles, roof subsidence and stoping, and timing of extensional shear zones in the City of Rocks National Reserve, Albion Mountains, southern Idaho, *in* Spangler, L.E., and Allen, C.J., eds., Geology of northern Utah and Vicinity, Utah Geological Association, p. 11-26.